

Ventilation Equipment
Condensation hood for 6 on 6 GN 2/1 or
6 on 10 GN 2/1 stacked electric
lengthwise combi ovens

ITEM # _____

MODEL # _____

NAME # _____

SIS # _____

AIA # _____

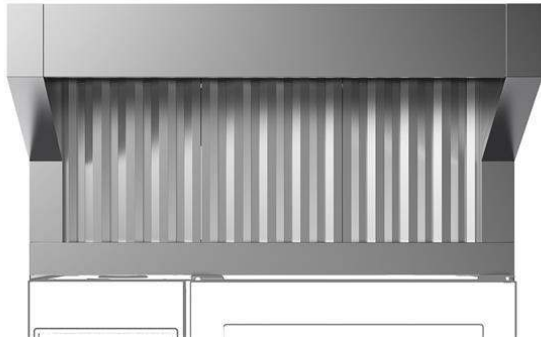
922726 (HOCS21E)

 Condensation hood with fan
 for stacking 6+6 or 6+10 GN
 2/1 electric ovens

Short Form Specification

Item No. _____

- Constructed in 304 AISI stainless steel
- Steam condensation device
- Equipped with labyrinth filters in 304 AISI stainless steel (positioned on front), condensation filter and extra droplets separator acting as a steam-liquid separator
- Built-in fan which automatically controls the air capacity according with the quantity of steam produced
- The frontal ventilation is activated when the door of the oven is opened and thanks to a direct software connected to the oven, the hood automatically activates fan power and odor absorption based on real oven activity
- Suitable for installation on 6 on 6 GN 2/1 or 6 on 10 GN 2/1 STACKED ELECTRIC LW COMBI OVENS.

Main Features

- Filtering surface protects against fire hazard.
- No need for an external exhaust pipe, thus eliminating carpentry costs.
- Complete ventilation system which eliminates the need for an exhaust duct with external connection.
- Fan motor with 3 automatic speeds:
 - Low speed when door is closed and valve is closed;
 - Medium speed when door is closed and valve is open;
 - High speed when door is open.
- Frontal labyrinth and condensation filters are easy to remove and cleanable in a dishwasher.
- The cable connection between the hood and the oven makes possible the communication between them. Connection of the hood to the oven's software automatically activates fan power and odour absorption based on real oven activity.
- The hood and the oven are synchronized: the hood switches On/Off when the oven starts/stops; based on real oven activity the hood automatically activates Hi/Medium/Low fan power for odour absorption.
- Can be used with 6 on 6 GN 2/1 or 6 on 10 GN 2/1 stacked electric LW combi ovens.
- Double step door opening (PNC 922265) is suggested to improve filtering performance.

Construction

- Constructed entirely in 304 AISI stainless steel.
- Automatic door opening activation system.
- Multiple filtration systems:
 - prefiltering of exhaust steam through stainless steel labyrinth filters;
 - condensation filter and extra droplets separator acting as a steam-liquid separator.
- Developed and produced in ISO 9001, ISO 14001 and ISO 50001 certified factory.
- Must be installed in a space where normal aeration, according to regulations, is present.

Sustainability

- System guarantees correct suction as well as high energy saving.

APPROVAL: _____

Front

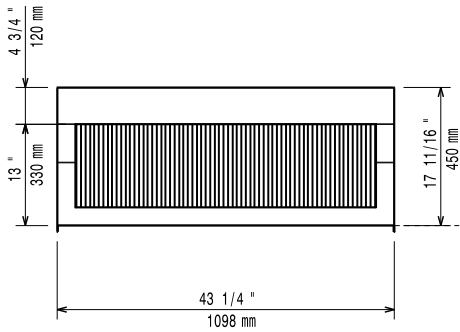

Side

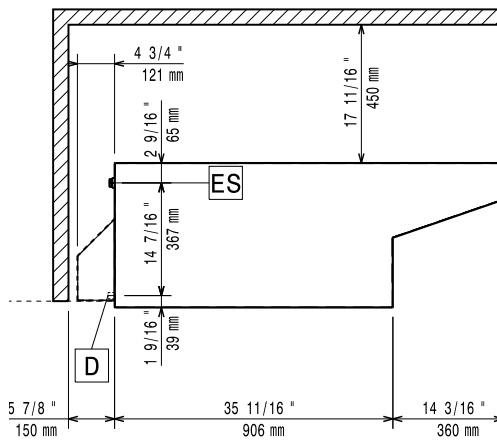

D = Drain
 EI = Electrical inlet (power)

Top

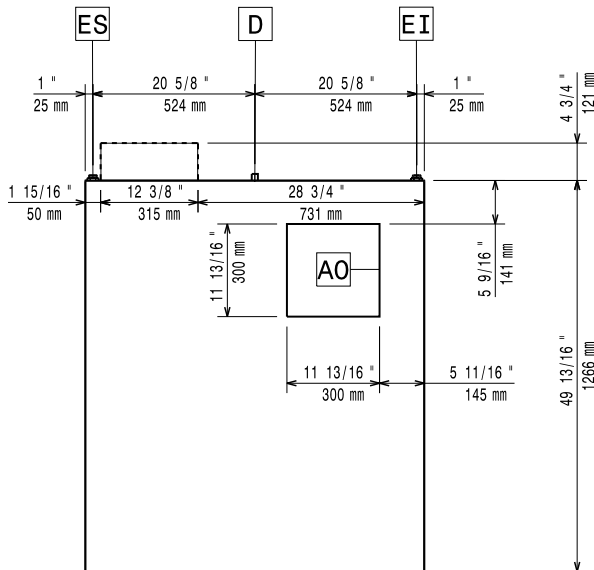

Electric

Supply voltage:

922726 (HOCS21E) 230 V/1 ph/50 Hz

Default Installed Power:

0.4 kW

Key Information:

External dimensions, Width: 1098 mm

External dimensions, Depth: 1266 mm

External dimensions, Height: 450 mm

Net weight: 86 kg

Shipping weight: 86 kg